

Parallel Hand Grips

Bores from 10 to 32 mm

Double acting



Executions		
Version	Code	Item
Bore 10 mm	075025	10PPB
Bore 16 mm	075027	16PPB
Bore 20 mm	075063	20PPB
Bore 25 mm	075028	25PPB
Bore 32 mm	075029	32PPB

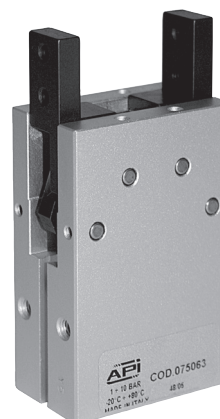

Series of pneumatic parallel hand grips available in 5 different sizes.

They are standard magnetic with grooves on the body allowing the direct mounting of magnetic reed switches.

For magnetic reed switch type ASC see from page 1.110.1.
For mounting accessories see from page 1.80.60.

How to order : 16PPB

16	PPB
Bore	Type

Technical data						
Type	10PPB	16PPB	20PPB	25PPB	32PPB	
Fluid	Compressed filtered air					
Pressure range	1,5 ÷ 7 bar					
Temperature range	0 °C ÷ + 80°C					
Max. operation frequency	180 cycle / min.					
Lubrication	Piston : with or without lubrication					
	Levers : lubrication is required on moving parts					
Theoretical holding force M* (N)	Closing	5	18	35	60	85
	Opening	8	24	47	75	100
Maximum length of gripping point L (mm)	30	40	60	70	85	
Weight (g)	50	140	250	410	680	
Stroke of open/close (mm)	4	8	12	14	16	
Ports	M3	M5				

* Gripping point 30 mm at 5 bar

Materials

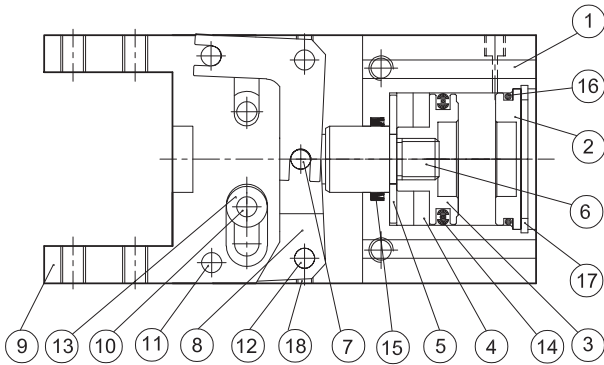

N.	Component	Material
1	Body	Aluminium
2	End cover	Brass
3	Piston	Brass
4	Magnet	Plastic magnet
5	Magnet holder	Brass
6	Piston rod	Stainless steel
7	Piston rod pin	Steel
8	Action lever	Steel alloy
9	Fingers	Steel alloy
10	Slide guide pin	Steel
11	Slide pin	Steel
12	Action lever pin	Steel
13	Ring	Steel alloy
14	Piston seal	NBR
15	Piston rod seal	NBR
16	End cover O-ring	NBR
17	Seeger	Steel
18	Hexagonal screw	Steel alloy

Gripping forces

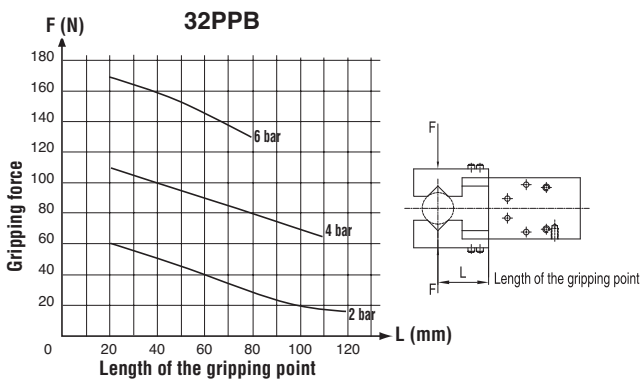
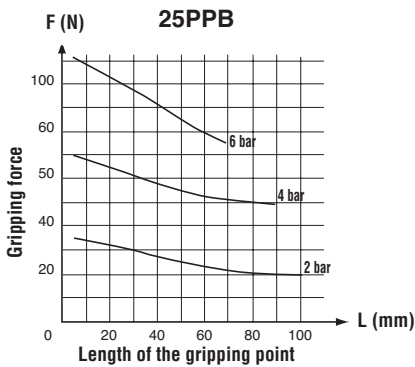
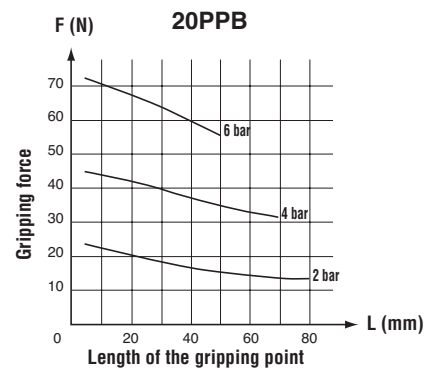
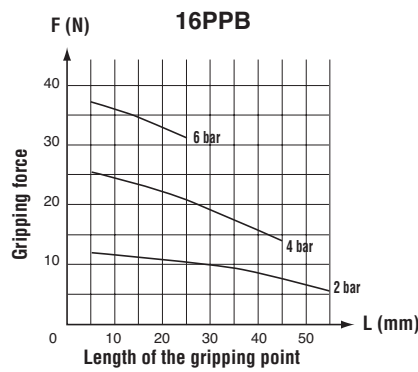
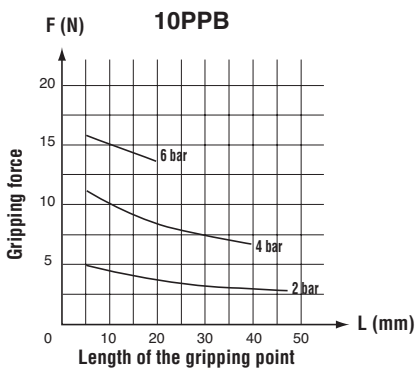

type: 10PPB

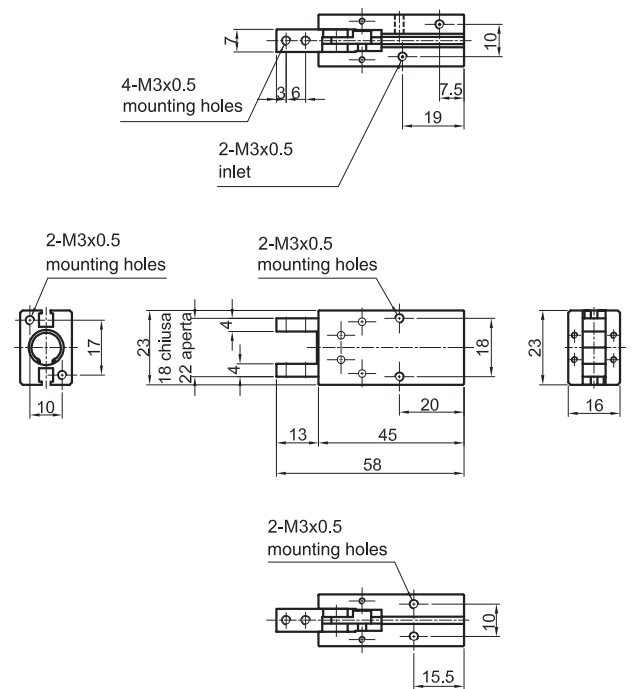

type: 16PPB

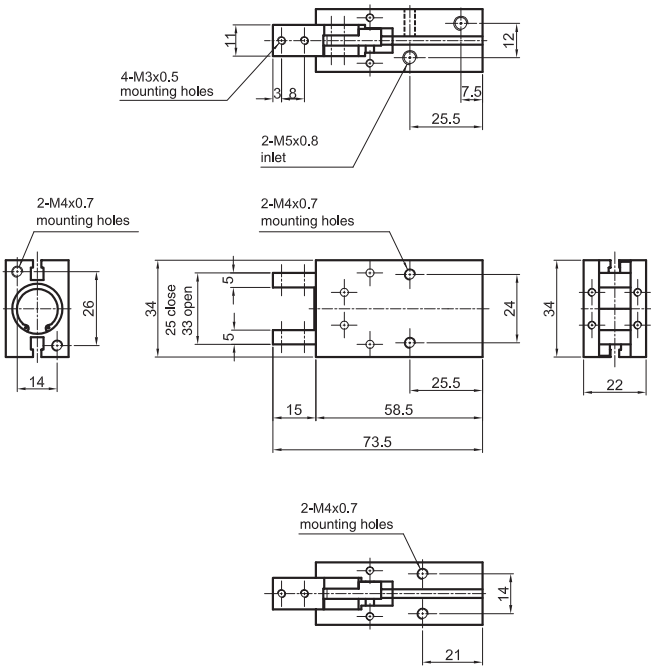

type: 20PPB

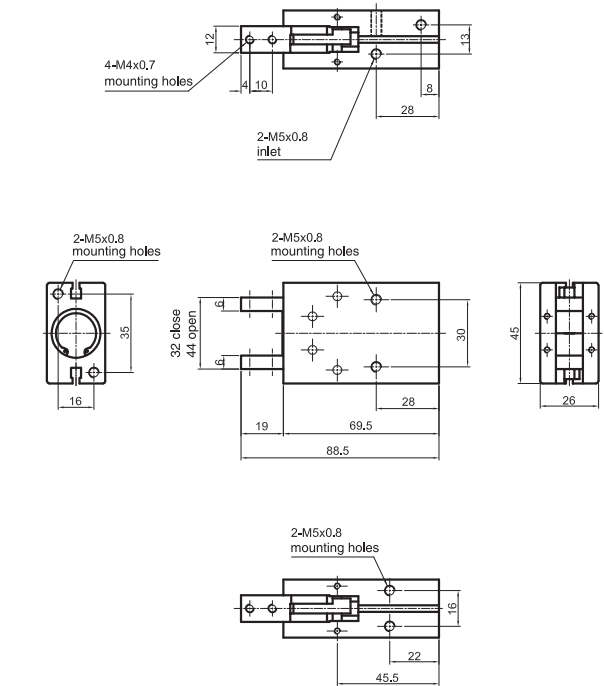

type: 25PPB

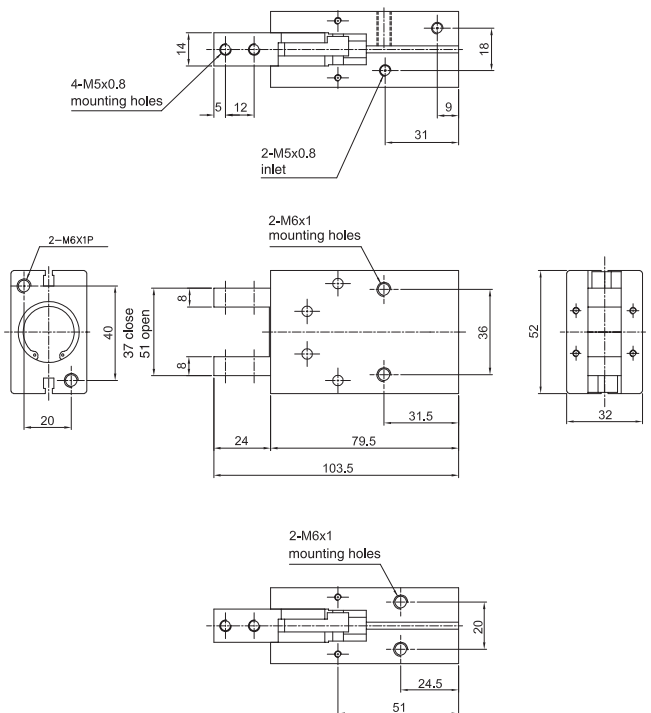

type: 32PPB

